

Transfer Policy Review Working Group Recap

Where are we now?



GROUP 2

- Transfer Emergency Action Contact (TEAC)
- Transfer Dispute Resolution Policy (TDRP)
- EPDP Phase 1, Recommendation 27, Wave 1 as they relate to TEAC/TDRP
- ICANN-Approved Transfers



Group 2: (TEAC) Recommendation Refresher



Prelim. Rec. 1: Section I.A.4.6.3 of the Transfer Policy states, “Messages sent via the TEAC communication channel must generate a non-automated response by a human representative of the Gaining Registrar. The person or team responding must be capable and authorized to investigate and address urgent transfer issues. Responses are required within 4 hours of the initial request, although final resolution of the incident may take longer.” The working group recommends that the policy must be revised to ***update the required timeframe for initial response from 4 hours to 24 hours / 1 calendar day.***

IN SHORT: TIMING CHANGE (4 hours to 24 hours)



Group 2: (TEAC) Recommendation Refresher



Prelim. Rec. 2: Section I.A.4.6.2 of the Transfer Policy states in part, “. . . Communications to a TEAC must be initiated in a timely manner, within a reasonable period of time following the alleged unauthorized loss of a domain.” The working group recommends that the Transfer Policy must be updated to state that the ***initial communication to a TEAC is expected to occur no more than 30 days following the alleged unauthorized loss of a domain.*** If the initial communication to the TEAC occurs more than 30 days following the alleged unauthorized loss of a domain, the Losing Registrar must provide a detailed written explanation to the Gaining Registrar’s TEAC justifying why this is an emergency situation that must be addressed through the TEAC channel and providing information about why earlier contact to the TEAC was not possible.

IN SHORT: NEW REGISTRAR REQUIREMENT



Group 2: (TEAC) Recommendation Refresher



Prelim. Rec. 3: Once a Gaining Registrar has provided an initial non-automated response to a TEAC communication as described in Section I.A.4.6.3 of the Transfer Policy, the Gaining Registrar must provide additional, ***substantive updates by email to the Losing Registrar at least every 72 hours / 3 calendar days until work to resolve the issue is complete.*** These updates must include specific actions taken by the Gaining Registrar to work towards resolution.

IN SHORT: NEW REGISTRAR REQUIREMENT



Group 2: (TEAC) Recommendation Refresher



Prelim. Rec. 4: The working group recommends that *initial communication to the TEAC described in Section I.A.4.6.2 of the Transfer Policy must either be in the form of email or, if the primary TEAC communication channel is designated as a phone number or other method, the verbal/non-email communication must be accompanied by an email communication to the TEAC.* This email “starts the clock” for the 24-hours response timeframe specified in Preliminary Recommendation 1. The Gaining Registrar receiving the TEAC communication must respond by email within 24 hours.

IN SHORT: NEW REGISTRAR REQUIREMENT



Group 2: (TEAC) Recommendation Refresher



NOTE: The Working Group discussed the possibility of a **“fast undo” mechanism or clawback mechanism**, but **could not come to agreement** on pursuing this further.

- A Small Team worked on drafting a process of how informal resolution occurs today, and how the process could potentially be added to the Transfer Policy as a fast undo mechanism.
- After presenting the [proposed process](#) to the Working Group, the majority of members believed there was no compelling reason to add the informal resolution to the Transfer Policy, as it appears to be working today as a “fast undo”.
- The WG instead pivoted to TEAC requirements to see if they could be amended to assist with fast resolution. (Some requirements in the [fast undo proposed process](#) have been added to new TEAC requirements, e.g., 1, 3, 5.)

Group 2: (TDRP) Recommendation Refresher



Prelim. Rec. 1: The Working Group recommends the *GNSO request an Issues Report* or other suitable mechanism to further research and explore the pros and cons of (i) expanding the TDRP to registrant filers and (ii) ***creating a new standalone dispute resolution mechanism for registrants who wish to challenge improper transfers, including compromised and stolen domain names.*** In making this recommendation, the Working Group recognizes that if such an effort were ultimately adopted by the GNSO Council, this request could be resource-intensive and will require the Council to consider the appropriate timing and priority against other policy efforts.

IN SHORT: REQUEST TO GNSO



Group 2: (TDRP, Rec. 27) Recommendation Refresher



Prelim. Rec. 3: The working group recommends the following specific terminology updates to the Transfer Dispute Resolution Policy:

- (i) The term "Whois data" SHALL have the same meaning as "Registration Data".
- (ii) The term "Whois details" SHALL have the same meaning as "Registration Data".
- (iii) The term "Publicly accessible Whois" SHALL have the same meaning as "RDDS".
- (iv) The term "Whois" SHALL have the same meaning as "RDDS".

For the avoidance of doubt, the terms referenced in above in Recommendation 14 (i) - (iv) are intended to correspond to the definitions in the Registrar Accreditation Agreement ("RAA"). In the event of any inconsistency, the RAA definitions, if updated, will supersede. The working group also recommends that the outdated terms should be replaced with the updated terms, e.g., all references to "Whois Data" should be replaced with the term "Registration Data," etc.

IN SHORT: TERMINOLOGY UPDATE



Group 2: (ICANN-Approved Transfers) Recommendation Refresher

- There has been some general confusion in the WG re: bulk transfers, so we will be using some explanatory icons to aid understanding. There are three types of bulk transfers:

1. A registrar is transferring ALL of its gTLD domains to another registrar, because it will no longer operate as a registrar (on a voluntary or involuntary basis). This is akin to a farmer selling their entire farm to a buyer.



2. A registrar is transferring all of its names in a certain gTLD(s) because it will no longer offer those TLDs but will continue operating as a registrar with other approved TLDs, i.e., an RRA is voluntary or involuntarily terminated. This is akin to a farmer deciding to sell all of their cattle to an interested buyer (with no intent in raising cattle anymore), but the farmer will keep growing crops and raising other animals. *Note: there are no specific recommendations for this scenario, but is included for illustrative purposes only.*



3. A registrar sells off a portion of its domain name portfolio to another registrar, but will continue offering all of the same TLDs. This is akin to a farmer selling one its cows, but still has cattle and continue to acquire new cattle.



Group 2: (ICANN-Approved Transfers) Recommendation Refresher



Prelim. Rec. 1: i) The Working Group recommends that a Registry Operator MAY charge a fee to implement a full domain name portfolio transfer of 50,000 or more domain names from one ICANN-accredited registrar to another ICANN-accredited registrar(s), provided the required conditions are satisfied.* (ii) The **Registry MAY waive the fee** associated with full portfolio transfers; however, **in full portfolio transfers resulting from an involuntary registrar termination**, i.e., where a registrar is terminated by ICANN due to non-compliance with the Registrar Accreditation Agreement, the Working Group recommends the **Registry MUST waive any fee** associated with a full portfolio transfer.

IN SHORT: UPDATE TO REGISTRY REQUIREMENT



*The required conditions provided in the Transfer Policy are, “The gaining Registrar must be accredited by ICANN for the Registry TLD and must have in effect a Registry-Registrar Agreement with Registry Operator for the Registry TLD [and] 1.2 ICANN must certify in writing to Registry Operator that the transfer would promote the community interest, such as the interest in stability that may be threatened by the actual or imminent business failure of a Registrar.”

Group 2: (ICANN-Approved Transfers) Recommendation Refresher



Prelim. Rec. 2: The Working Group recommends retaining both (i) the current minimum number of domain names that trigger the fee at 50,000 names and (ii) the current price ceiling of USD \$50,000. If the full portfolio transfer involves multiple Registry Operators, ***the affected Registry Operators MUST ensure the collective fee does not exceed the recommended ceiling of USD \$50,000, and the fee MUST be apportioned based on the number of domain names transferred.*** [Please see recs. 3-6 for further information on the apportionment.]



IN SHORT: UPDATE TO REGISTRY REQUIREMENT



Group 2: (ICANN-Approved Transfers) Recommendation Refresher



Prelim Rec. 4: The Working Group recommends that if the full portfolio transfer involves multiple Registry Operators, and one or more affected Registry Operators chooses to waive its portion of the collective fee, *the remaining Registry Operator(s) MUST NOT adjust their fees to a higher percentage due to another Registry Operator's waiver.*



IN SHORT: UPDATE TO REGISTRY REQUIREMENT



Group 2: (ICANN-Approved Transfers) Recommendation Refresher



Prelim. Rec. 5: The Working Group recommends that following the completion of the transfer, the **Registry Operator(s) MUST provide notice to ICANN that the transfer is complete, and the notice to ICANN MUST include the number of domain names transferred.**



IN SHORT: NEW REGISTRY REQUIREMENT



Prelim Rec. 6: The Working Group recommends that following receipt of notices from all affected Registry Operators, **ICANN MUST send a notice to affected Registry Operators with the reported numbers and corresponding percentages of domain names involved in the bulk transfer**, e.g., 26% of names for .ABC and 74% of names for .DEF. The Registry Operators MAY then charge the Gaining Registrar a fee.



IN SHORT: NEW ICANN REQUIREMENT



Group 2: (ICANN-Approved Transfers) Recommendation Refresher



Prelim. Rec. 7: The Working Group recommends that the Gaining Registrar **MUST** be responsible for paying the relevant Registry's fee (if any)



IN SHORT: CONFIRMATION OF EXISTING REQUIREMENT



Group 2: BTAPPA Recommendations Refresher



Prelim. Rec. 1: The Working Group recommends that [the standard Bulk Transfer After Partial Portfolio Acquisition (BTAPPA)] ***be expanded to include circumstances where an agent of the Registrar, such as a Reseller or service provider who is acting under the authority or on behalf of the Registered Name Holder, elects to transfer its portfolio of domain names to a new Gaining Registrar***, and this type of transfer is permissible under the relevant agreements.



IN SHORT: NEW REGISTRY REQUIREMENT



Prelim Rec. 2: The Working Group recommends that in the event a change of sponsorship is permitted by the Registry Operator, ***Registrars shall either notify or ensure their Resellers (where applicable) notify affected Registrants approximately one month before the change of sponsorship is expected to occur***. This notification must provide instructions on (i) how to opt out (if applicable) (ii) how to transfer the name to a Registrar other than the Gaining Registrar , (iii) the expected date of the change of sponsorship, (iv) the name of the Gaining Registrar, and (v) a link to the Gaining Registrar's (or their Reseller's) terms of service.



IN SHORT: NEW REGISTRAR REQUIREMENT



Group 2: BTAPPA Recommendation Refresher



Prelim. Rec. 3: The Working Group recommends that for a change of sponsorship, the expiration dates of transferred registrations are not affected and, therefore, there are no ICANN fees. Once the change of sponsorship is complete, there is no grace period to reverse the transfer.

IN SHORT: CONFIRMATION OF EXISTING BTAPPA BOILERPLATE



Prelim Rec. 4: The Working Group recommends a Registry Operator ***MUST reject a change of sponsorship request if there is reasonable evidence that the change of sponsorship is being requested in order to avoid fees otherwise due to the Registry Operator or ICANN.*** A Registry Operator has discretion to reject a change of sponsorship request if a registrar with common ownership or management or both has already requested a change of sponsorship within the preceding six-month period.

IN SHORT: CONFIRMATION OF EXISTING BTAPPA BOILERPLATE



Group 2: BTAPPA Recommendation Refresher



Prelim. Rec. 5: The Working Group recommends that the *Losing Registrar's existing Registration Agreement with customers MUST permit the transfer of domain names in the event of the scenarios described in the Transfer Policy with respect to a change of sponsorship*. Additionally, the Losing Registrar's Registration Agreement must inform registrants that in the event of a change of sponsorship, the affected registrants will be deemed to have accepted the new registrar's terms, unless the registrant transfers their domain name(s) to a different registrar prior to the change of sponsorship.



IN SHORT: NEW REGISTRAR REQUIREMENT



Prelim Rec. 6: The Working Group recommends that the Registry Operator MAY charge a fee for a change of sponsorship, but Registry Operators MUST provide notice to Registrars of any fees associated with a change of sponsorship upon request and prior to the initiation of the transfer. How Registry Operators choose to provide notice of fees will be up to the Registry to decide, i.e., password protected portal, website, written notice, etc.



IN SHORT: NEW REGISTRY REQUIREMENT



Group 2: BTAPPA Recommendation Refresher



Prelim. Rec. 7: In the case of a change of sponsorship, the Gaining Registrar **MUST NOT** impose a new inter-registrar transfer lock preventing affected registrants from transferring their domains to another Registrar.



IN SHORT: NEW REGISTRAR REQUIREMENT



Group 2: (TEAC + TDRP + Bulk Transfers) Deliberations Refresher

TPR WG Resources:

- ❖ [Transfer Policy](#), Section I.A.4.6, I.B
- ❖ [Transfer Dispute Resolution Policy](#)
- ❖ [TEAC Working Document](#)
- ❖ [TDRP Working Document](#)
- ❖ [Rec. 27 TDRP Working Document](#)
- ❖ [ICANN-Approved Transfers Working Document](#)

GROUP 1(A)



- Losing and Gaining FOAs
- AuthInfo Codes
- Denying (NACKing) transfers
- EPDP Phase 1, Recommendation 27, Wave 1 as they relate to FOA

Group 1(A): TPR Swimlane Overview

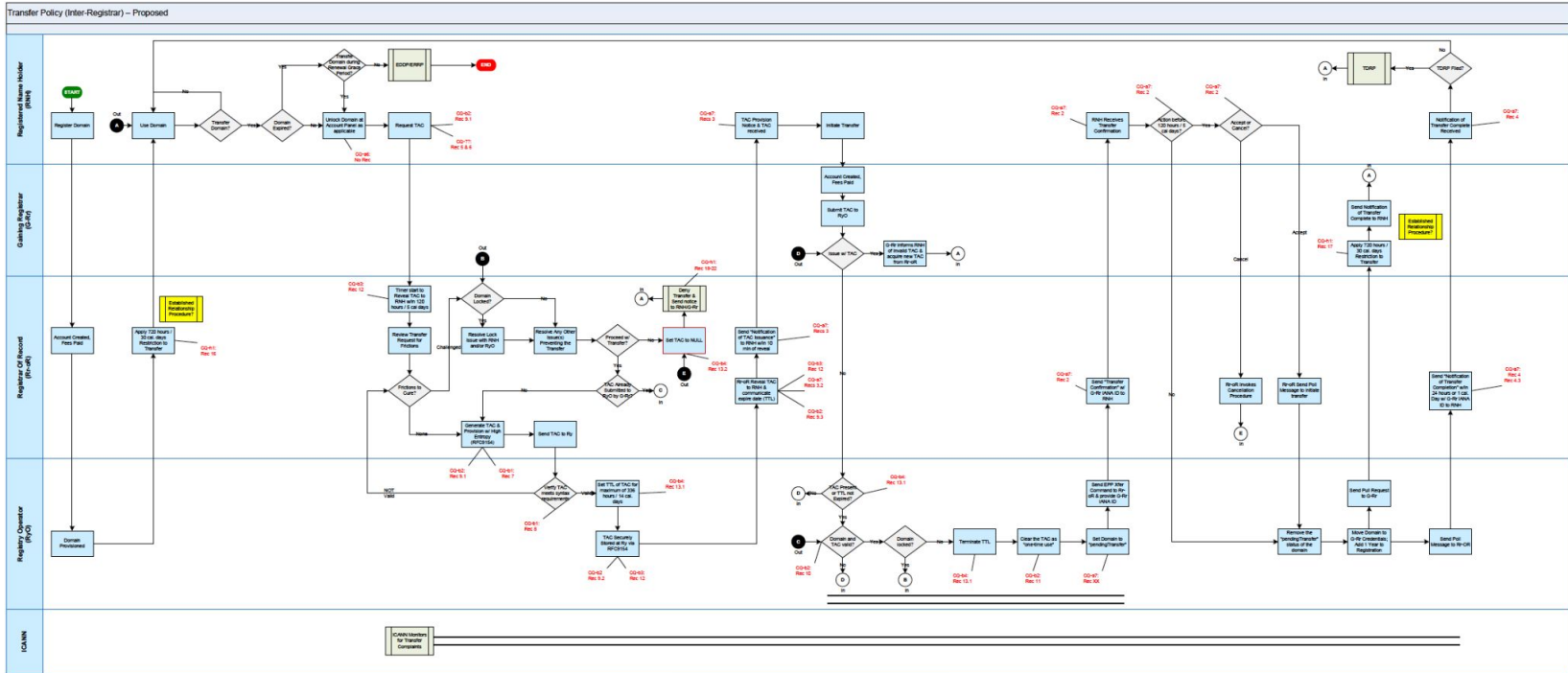

Staff recommends listening to the [TPR call on 17 Jan 2023](#) for an overview of the proposed transfer process and to understand changes made to the latest version, v1.4. This will better prepare you for the review of the preliminary recommendations in Group 1(A) below. Link to latest v1.4 [swimlane](#).

Group 1(A): (FOAs) Recommendation Refresher



Prelim. Rec. 1: The working group recommends *eliminating* from the Transfer Policy *the requirement* that the Gaining Registrar *send a Gaining Form of Authorization*. This requirement is detailed in section 1.A.2 of the Transfer Policy.

In Short: GAINING FOA REQUIREMENT IS REMOVED



Group 1(A): (FOAs) Recommendation Refresher



Prelim. Rec. 2: The working group did not reach agreement to eliminate or substantially change the Obligations of the Registrar of Record described in Section I.A.3.1 - I.A.3.6 of the Transfer Policy. Therefore, the working group anticipates that these requirements will largely remain in place. The working group recommends the following minor modifications:

- ***The term “Transfer Confirmation” MUST be used in place of “Standardized Form of Authorization (FOA).”***
- The Transfer Confirmation language MUST include the ***Gaining Registrar’s IANA ID and a link to ICANN-maintained webpage listing accredited Registrars and corresponding IANA IDs.*** If available, the name of the Gaining Registrar MAY also be included.
- The Transfer Confirmation ***MUST be provided in English*** and the language of the registration agreement and may also be provided in other languages.
- The ***timeframe of five (5) calendar days specified in section I.A.3.5 of the policy MUST be expressed in both calendar days and hours:*** “Failure by the Registrar of Record to respond within five (5) calendar days / 120 hours to a notification from the Registry regarding a transfer request will result in a default "approval" of the transfer.”

IN SHORT: UPDATED REGISTRAR REQUIREMENT



Group 1(A): (FOAs) Recommendation Refresher



Prelim. Rec. 3: Prelim. Rec. 3: The working group recommends that the Registrar of Record **MUST send a “Notification of T[ransfer] A[uthorization] C[ode] Issuance”** to the RNH without undue delay but no later than 10 minutes after the Registrar of Record issues the TAC. For the purposes of sending the notification, the Registrar of Record **MUST** use contact information as it was in the registration data at the time of the TAC request.

- **MUST** be provided *in English and language of registration agreement*
- Notice **MUST** include:
 - Domain Name
 - **Explanation that the TAC will enable the transfer of the domain name to another registrar**
 - Date and Time TAC was issued and when it will expire
 - **Instructions on how to take action/invalidate the TAC**
 - If the TAC has not been issued via another method of communication, the communication will include the TAC

In short: NEW LOSING REGISTRAR NOTIFICATION REQUIREMENT



Group 1(A): (FOAs) Recommendation Refresher



Prelim. Rec. 4: The working group recommends that the **Losing Registrar MUST send a “Notification of Transfer Completion”** to the RNH without undue delay but no later than 24 hours after the transfer is completed. For the purposes of sending the notification, the Registrar of Record MUST use contact information as it was in the registration data at the time of the transfer request.

In short: NEW LOSING REGISTRAR NOTIFICATION REQUIREMENT



Prelim. Rec. xx: The *Registry Operator MUST provide the Gaining Registrar’s IANA ID to the Losing Registrar* in the notification of pending transfer request, which will enable the Losing Registrar to provide this information in the Transfer Confirmation and Notification of Transfer Completion.

In short: NEW REGISTRY REQUIREMENT + NEW LOSING REGISTRAR REQUIREMENT



RECAP: High-Level Landing for FOAs



- No more Gaining FOA requirement

Required notices to be sent by Losing Registrar/Registrar of Record:

1. Notice of TAC Issuance (sent within 10 min of issuing TAC)
2. Notice of Transfer Confirmation (Losing FOA) (sent after notice of pending transfer is rec'd from Registry)
3. Notice of Transfer Completion (sent within 24 hours after transfer completion)



Group 1(A): (Auth Codes) Recommendation Refresher



Prelim. Rec. 5: The working group recommends that the Transfer Policy and all related policies **MUST** use the term “***Transfer Authorization Code (TAC)***” ***in place of the currently-used term “AuthInfo Code”*** and related terms. This recommendation is for an update to terminology only and does not imply any other changes to the substance of the policies.

IN SHORT: NEW DEFINITION



Prelim. Rec. 6: The working group recommends that the ***Transfer Authorization Code MUST be defined as follows:*** “A Transfer Authorization Code (TAC) ***is a token created by the Registrar of Record and provided upon request to the RNH*** or their designated representative. The TAC is ***required for a domain name to be transferred from one Registrar to another Registrar*** and when presented authorizes the transfer.” Relevant policy language **MUST** be updated to be consistent with this definition.

IN SHORT: NEW DEFINITION



Group 1(A): (Auth Codes) Recommendation Refresher



Prelim Rec. xx: The Registrar ***MUST retain all records pertaining to the provision of the TAC to a Registered Name Holder***, as well as all notifications sent per the requirements under the Transfer Policy. At a minimum, the records retained in accordance with this section ***MUST document the date/time, means, and contact(s) to whom the TAC and notifications are sent.*** The Registrar **MUST** maintain these records for the shorter of 15 months or the longest period permitted by applicable law, and during such period, **MUST** provide such records to ICANN upon reasonable notice.

IN SHORT: NEW REQUIREMENT FOR REGISTRARS



Group 1(A): (Auth Codes) Recommendation Refresher



Prelim Rec. 7: The working group recommends that the *minimum requirements for the composition of a TAC MUST be as specified in RFC 9154*, including all successor standards, modifications or additions thereto relating to Secure Authorization Information for Transfer. The requirement in section 4.1 of RFC 9154 regarding the minimum bits of entropy (i.e., 128 bits) should be a MUST in the policy until a future RFC approved as “Internet Standards” (as opposed to Informational or Experimental standards) through the applicable IETF processes updates the security recommendation.

IN SHORT: NEW REQUIREMENTS FOR TAC (Auth-Code)



Prelim Rec. 8: The working group recommends that, at the time that the TAC is stored in the Registry system, the *Registry MUST verify at the time the TAC meets the syntax requirements* specified in Preliminary Recommendation 7.

IN SHORT: NEW REQUIREMENT FOR REGISTRIES



Group 1(A): (Auth Codes) Recommendation Refresher

Prelim Rec. 9: The working group recommends that:



9.1: The *TAC MUST only be generated by the Registrar of Record upon request by the RNH* or their designated representative.

IN SHORT: NEW REQUIREMENT FOR REGISTRARS



9.2: When the Registrar of Record sets the TAC at the Registry, *the Registry MUST store the TAC securely, at least according to the minimum standard set forth in RFC 9154* (or its successors).

IN SHORT: NEW REQUIREMENT FOR REGISTRIES



9.3: When the Registrar of Record issues the TAC to the RNH or their designated representative, *the Registrar of Record MUST also provide information about when the TAC will expire.*

IN SHORT: NEW REQUIREMENT FOR REGISTRARS



Group 1(A): (Auth Codes) Recommendation Refresher



Prelim. Rec. 10: The working group recommends that the Transfer Policy include the following requirement: ***“4. Registry Operator MUST verify that the “AuthInfo” code provided by the Gaining Registrar is valid in order to accept an inter-Registrar transfer request,”***

IN SHORT: CONFIRMATION OF CURRENT TEMP SPEC REQUIREMENT



Prelim. Rec. 11: The working group recommends that the TAC as created by the Registrar of Record according to Preliminary Recommendation 7, ***MUST be “one-time use.”*** In other words, it MUST be used no more than once per domain name. ***The Registry Operator MUST reset the TAC to null when it accepts a valid TAC from the Gaining Registrar.***

IN SHORT: NEW REQUIREMENT FOR REGISTRIES



Group 1(A): (Auth Codes) Recommendation Refresher



Prelim. Rec. 12: The working group confirms that the Transfer Policy **MUST** continue to require Registrars to set the TAC at the Registry and issue the TAC to the RNH or their designated representative ***within five calendar days of a request***, although the working group recommends that the policy state the requirement as ***120 hours rather than 5 calendar days to reduce any risk of confusion***. The working group further recommends that the policy **MUST** make clear that 120 hours is the maximum and not the standard period in which the TAC is to be issued.

IN SHORT: CONFIRMATION OF CURRENT REGISTRAR REQUIREMENT



Prelim. Rec. 13: The working group recommends that:

13.1: A standard ***Time to Live*** (TTL) for the TAC **MUST** be valid for ***14 calendar days / 336 hours*** from the time it is set at the Registry, enforced by the Registry.

13.2: The Registrar of Record ***MAY reset the TAC to null prior to the end of the 14th calendar day / 336 hours by agreement by the Registrar of Record and the RNH.***

IN SHORT: NEW REGISTRY REQUIREMENT



RECAP: High-Level Landing for TACs



- **New Term + Updated definition (token created by LR and needed to transfer a name to a different registrar)**
- **Minimum composition requirements**
- **Registry to verify syntax**
- **Generated only upon request**
- **Stored securely**
- **Retain records of communication related to TAC for 15 months**
- **Must be provided within 5 days/120 hrs of request**
- **Standard TTL**

Group 1(A): (Wave 1) Recommendation Refresher



Prelim. Rec. 14: The working group recommends the following specific terminology updates to the Transfer Policy:

- (i) The term "Whois data" SHALL have the same meaning as "Registration Data".
- (ii) The term "Whois details" SHALL have the same meaning as "Registration Data".
- (iii) The term "Publicly accessible Whois" SHALL have the same meaning as "RDDS".
- (iv) The term "Whois" SHALL have the same meaning as "RDDS".

For the avoidance of doubt, the terms referenced in above in Recommendation 14 (i) - (iv) are intended to correspond to the definitions in the Registry Agreement and the Registrar Accreditation Agreement ("RAA"). In the event of any inconsistency, the RA/RAA definitions, if updated, will supersede. The working group also recommends that the outdated terms should be replaced with the updated terms, e.g., all references to "Whois Data" should be replaced with the term "Registration Data," etc.

IN SHORT: CONFIRMATION OF TEMP SPEC REQUIREMENT



Group 1(A): (Wave 1) Recommendation Refresher



Prelim. Rec. 15: The working group recommends *removing any reference to an “Administrative Contact” or “Transfer Contact”* in the Transfer Policy and *replacing it with “Registered Name Holder”* unless specifically indicated.

IN SHORT: LANGUAGE/DEFINITIONAL UPDATE



Group 1(A): NACK-ing Recommendation Refresher



Prelim. Rec. 16: The *Registrar MUST restrict the RNH from transferring a domain name to a new Registrar within 30 calendar days / 720 hours of the initial registration date.* To the extent that a Registry and/or Registrar has an existing policy and/or practice of restricting the RNH from transferring a domain name to a new Registrar for a different period of time following initial registration, all policies and practices MUST be updated to be consistent with this new requirement.

IN SHORT: TIMING CHANGE (60 days to 30 days)



Prelim. Rec. 17: The *Registrar MUST restrict the RNH from transferring a domain name to a new Registrar within 30 calendar days / 720 hours of the completion of an inter-Registrar transfer.* To the extent that a Registry and/or Registrar has an existing policy and/or practice of restricting the RNH from transferring a domain name to a new Registrar for a different period of time following an inter-Registrar transfer, all policies and practices MUST be updated to be consistent with this new requirement.

IN SHORT: TIMING CHANGE (60 days to 30 days)



*** the WG has yet to settle the concept of “Established Relationship Procedure” pending deliberations on Group 2 and 1B topics*

Group 1(A): NACK-ing Recommendation Refresher



Prelim. Rec. 18: I.A.3.7 of the Transfer Policy currently reads, “Upon denying a transfer request for any of the following reasons, the Registrar of Record must provide the Registered Name Holder and the potential Gaining Registrar with the reason for denial. The Registrar of Record MAY deny a transfer request only in the following specific instances:” The working group recommends the following revision, in bold, to the first sentence: “Upon denying a transfer request for any of the following reasons, the Registrar of Record must provide the Registered Name Holder and, **upon request**, the potential Gaining Registrar with the reason for denial.” ***The working group recommends expressing the two sentences of this provision as two distinct provisions of the policy.***

IN SHORT: LANGUAGE UPDATE



Group 1(A): NACK-ing Recommendation Refresher



Prelim. Rec. 19: The working group recommends revising the following reasons that the Registrar of Record MAY deny a transfer request as follows:

1. Evidence of *(a) fraud or (b) the domain presents an active DNS Security Threat as defined here: <https://www.icann.org/dns-security-threat>.*
2. Reasonable **concern that the transfer was not requested** by the Registered Name Holder.
3. Nonpayment for previous registration period (including **payment disputes** or credit card charge-backs) if the domain name is past its expiration date **at the current Registrar of Record** or for previous or current registration periods if the domain name has not yet expired.

IN SHORT: LANGUAGE CLARIFICATION



Group 1(A): NACK-ing Recommendation Refresher



Prelim. Rec. 20: The working group recommends changing the following reasons that the Registrar of Record currently MAY deny a transfer into reasons that the Registrar of Record MUST deny a transfer and revising the text as follows:

- Express objection to the transfer by the **Registered Name Holder**. Objection could take the form of specific request (either by paper or electronic means) by the **Registered Name Holder** to deny a particular transfer request, or a general objection to all transfer requests received by the Registrar, either temporarily or indefinitely. In all cases, the objection must be provided with the express and informed consent of the **Registered Name Holder** on an opt-in basis and upon request by the **Registered Name Holder**, the Registrar must remove the lock or provide a reasonably accessible method for the **Registered Name Holder** to remove the lock within five (5) calendar days.
- The transfer was requested within **30 days** of the creation date as shown in the **RDDS** record for the domain name.
- A domain name is within **30 days** (or a lesser period to be determined) after being transferred (apart from being transferred back to the original Registrar in cases where both Registrars so agree and/or where a decision in the dispute resolution process so directs). "Transferred" shall only mean that an inter-registrar transfer has occurred in accordance with the procedures of this policy.

IN SHORT: LANGUAGE CLARIFICATION + TIMING UPDATE



Group 1(A): NACK-ing Recommendation Refresher



Prelim. Rec. 21: The working group recommends revising the reasons that the Registrar of Record **MUST** deny a transfer request as follows:

- Pending UDRP proceeding that the Registrar has been ***notified of by the Provider in accordance with the UDRP Rules.***
- Pending dispute ***under*** the Transfer Dispute Resolution Policy.
- ***Pending*** URS proceeding or URS suspension that the Registrar has been ***notified of by the Provider in accordance with the URS Procedure.***

IN SHORT: LANGUAGE CLARIFICATION



Group 1(A): NACK-ing Recommendation Refresher



Prelim. Rec. 22: The working group recommends changing the following reasons that the Registrar of Record currently MAY NOT deny a transfer into reasons that the Registrar of Record **MUST NOT** deny a transfer and revising the text as follows:

- [Nonpayment for a pending or future registration period.] Implementation Guidance: Registrars are prohibited from denying domain name transfer requests based on non-payment of fees for pending or future registration periods during the Auto-Renew Grace Period, provided that any auto-renewal costs borne by the Registrar are reversible for future period.
- No response from the Registered Name Holder.
- ***A registrar-applied inter-registrar transfer lock is in place*** on the domain name, for reasons other than those specified in I.A.3.7 and I.A.3.8 unless ***and*** the Registered Name Holder is **not** provided with the reasonable opportunity and ability to unlock the domain name prior to the Transfer Request ***pursuant to the requirements in sections I.A.5.1 - I.A.5.4.***
- Domain name registration period time constraints, other than ***as defined in I.A.3.7.5 and I.A.3.7.6***, or during the 60-day lock following a Change of Registrant pursuant to Section II.C.2.
- General payment defaults between Registrar and ***Reseller, as defined in the RAA***, in cases where the Registered Name Holder for the domain in question has paid for the registration.

IN SHORT: LANGUAGE CLARIFICATION



Group 1(A): (FOA+NACK-ing) Deliberations Refresher

TPR WG Resources:

- ❖ [Transfer Policy](#), Section I
- ❖ [Gaining FOA Working Document](#)
- ❖ [Losing FOA Working Document](#)
- ❖ [Auth-Info Codes \(TAC\) Working Document](#)
- ❖ [Rec. 27 Working Document](#)
- ❖ [Updated Initial Report following Public Comment Review](#)

GROUP 1(B)

- Change of Registrant (CoR)



Group 1(B): (CoR) Deliberations Refresher

At the start of CoR discussions, WG members participated in a poll:

- **73%** of the WG believed **the CoR policy must be changed significantly** or is no longer necessary in its current form.
- **82%** responded affirmatively that the **principles and procedures from Phase 1(A) should carry into Phase 1(B)**.
 - Some WG members noted specifically that the security principles emphasized in Phase 1(A) should continue in the WG's assessment of CoR.

Group 1(B): (CoR) Deliberations Refresher

II.A. CoR Definitions

- ***The current definition of “Change of Registrant” is not fit for purpose.***
- The WG considered replacing “Change of Registrant” with “Change of Control”.
 - ***A “Change of Control” could be a change to contactability, the primary contact method, or “anchor contact method”.***
 - The WG discussed establishing baseline requirements or enabling Registrars to determine for themselves their primary/anchor contact method(s).
- The definition/identifiers of a ***“Material Change” should be revisited*** to determine whether they are fit for purpose

IN SHORT: NEW DEFINITION/TERMINOLOGY (TBD)



Group 1(B): (CoR) Deliberations Refresher

II.B. Availability of CoR

- ***The CoR process should not apply*** [or a Registrar must deny a CoR] ***if there is evidence of (a) fraud or (b) the domain presents an active DNS Security Threat*** as defined here: <https://www.icann.org/dns-security-threat>.
 - *Alignment with Phase 1(A) Prelim. Rec. 19

IN SHORT: LANGUAGE ADDITION (TBD)  

Group 1(B): (CoR) Deliberations Refresher

II.C. CoR Process

- ***In the event of a CoR, a notification should be sent to the prior registrant [and new registrant] rather than a confirmation request.***
 - The WG noted that the lack of publicly available RDDS data since GDPR + increased TAC security in Phase 1(A) largely addresses security concerns.
 - A confirmation request does not necessarily protect against an already compromised account or contact, other than providing a notification/record of the change.

- ***The Registrar must process the CoR without undue delay, no longer than one calendar day (24 hours) of providing notification [to both parties].***

IN SHORT: LANGUAGE UPDATE (TBD)



Group 1(B): (CoR) Deliberations Refresher

II.C. CoR Process (60-day lock)

- ***The 60-day post-CoR lock should be eliminated.***
 - The lock is currently optional, so it provides no added security.
 - The lock causes significant confusion and frustration for registrants
 - If an inter-registrar transfer follows a CoR, Phase 1(A) 30-day post-transfer lock is sufficient
- If the WG decides to retain a post-CoR lock, the duration should be ***reduced to 30 days***
 - The WG noted that 60 days is too long
 - 30 days would be consistent with the locks in Phase 1(A).

IN SHORT: UPDATE TO LOCK REQUIREMENT (TBD)



Group 1(B): (CoR) Deliberations Refresher

The CoR discussion was **paused** for the 2022 summer break, to be resumed following Phase 2 discussions of a potential “fast undo” mechanism and enhancements to transfer dispute resolution mechanisms.

TPR WG discussion of CoR recommendations will continue in November 2023



Group 1(B): (CoR) Deliberations Refresher

TPR WG Resources:

❖ [CoR Triggers and Actions Matrix](#)

The screenshot shows a Google Sheet with the following columns:

- Trigger from Transfer Policy**
- Possible to Distinguish if the Update is a Topographical Correction?**
- Are current policy requirements fit for purpose?**
- Proposed Action, if any**
- Are current policy requirements fit for purpose?**
- Proposed Action, if any**
- Are current policy requirements fit for purpose?**
- Proposed Action**

The table contains three rows of data, each with a blue background for the trigger column. The first row is for 'IA.1.1.3 Prior Registrant name'. The second row is for 'IA.1.1.3.1 change to the Registrant Name (holder's name or organization) that does not appear to be merely a topographical correction'. The third row is for 'IA.1.1.3.1.1 change to the Registrant Name (holder's name or organization) that does not appear to be merely a topographical correction, but is a change of control'. The actions are categorized into 'Remains w/ Registrar & No Change of Control', 'In Close Proximity to or as Part of Change of Control', and 'Followed by Inter-Registrar Transfer'.

❖ [CoR Summary Document \(2023\)](#)

❖ [CoR - Overall Policy Working Document \(2022\)](#)

❖ [CoR - 60-Day Lock Working Document \(2022\)](#)

❖ [Transfer Policy, Section II](#)

❖ [Meeting Notes \(6/28/22 - 8/09/22\)](#)